

EX2SX-CVR

10G X2 TO SFP+ Converter Module

General Description

General Information	
Manufacturer Part Number	EX2-SFP+-CVR
Product Model	CVR-X2-SFP10G
Product Name	EX2-SFP+ Converter Module
Product Type	Transceiver
Features	<ul style="list-style-type: none"> ● XAUI Electrical Interface: 4 Lanes @ 3.125Gbit/s ● Hot Pluggable ● MDIO, DOM Support ● Compliant to X2 MSA ● Case operating temperature: 0 to 70 °C ● The EX2-SFP+-CVR Converter Module converts a 10 Gigabit Ethernet X2 port into a 10 Gigabit Ethernet SFP+ port. With the Converter Module, customers have the flexibility to use the 10 Gigabit X2 interface port of a switch with X2 modules or SFP+ modules.
I/O Expansions	
Number of Expansion Slots	1
Expansion Slots	(1 Total) SFP+
Network & Communication	
Network Technology	10GBase-X
Physical Characteristics	
Form Factor	Internal
Dimensions	19.4mmHeight x 42 Width x 91.1 Depth

Regulatory Compliance

Feature	Reference	Performance
Electrostatic discharge (ESD)	IEC/EN 61000-4-2	Compatible with standards
Electromagnetic Interference (EMI)	FCC Part 15 Class B EN 55022 Class B (CISPR 22A)	Compatible with standards
Laser Eye Safety	FDA 21CFR 1040.10, 1040.11 IEC/EN 60825-1, 2	Class 1 laser product
Component Recognition	IEC/EN 60950, UL	Compatible with standards
ROHS	2002/95/EC	Compatible with standards
EMC	EN61000-3	Compatible with standards

Package Outline

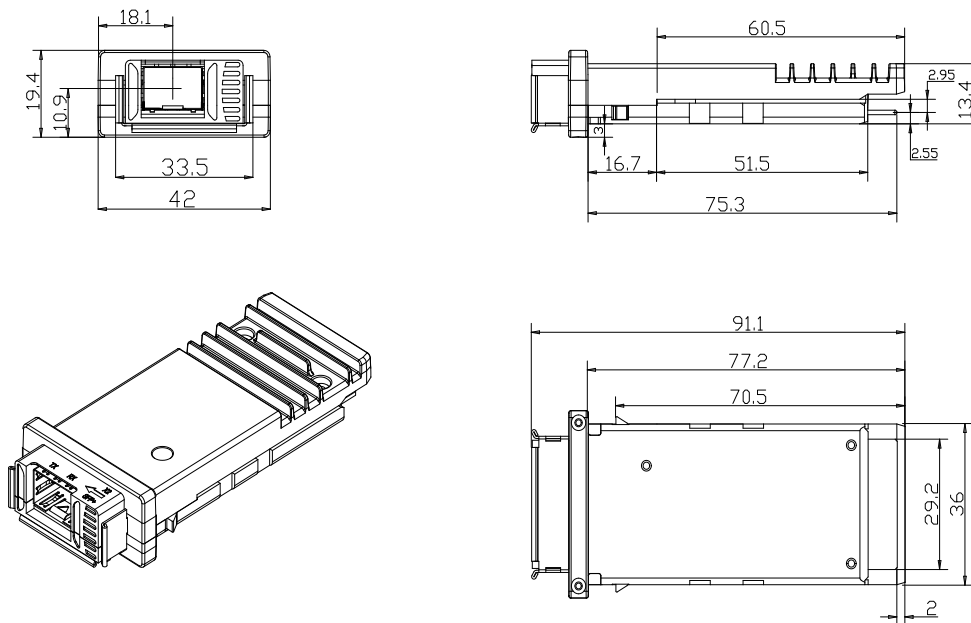

Compatibility Test

In order to ensure the product compatibility, our products will be tested on the switch before shipment. Our modules can compatible with many mainstream brand switches, such as Cisco, Juniper, Extreme, Brocade, IBM, H3C, HP, Huawei, D-Link, Mikrotik, ZTE, TP-Link...

Our test equipment: VOLKTEK MEN-4110, HP 2530-8G, CRS226-24G-25+RM, Catalyst 2960G Series, Catalyst 3850 XS 10G SFP+, Catalyst 3750-E Series, HUAWEI S5700Series, H3C S3100V2 Series,Juniper-EX4200, etc.



Cisco Catalyst 3850



HUAWEI S5700



H3C S3100V2



HP J9264AR



Juniper EX 4200



Alcatel 6850E-U24X



Mikrotik CR5226-24G-25+RM



Cisco Catalyst 2960G



Volktek MEN-4110

Product Production Process

Quality Assurance

Continuous introduction of new equipment, produced by strict standards, strict quality inspection, to guarantee the high quality standard of each product.



**Standardized
Production Line**



**Professional
Welding**



Assembling



Aging Testing

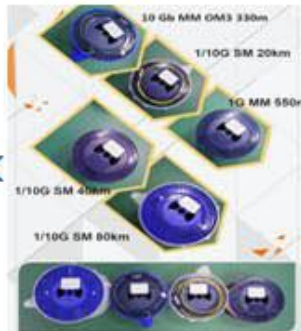

Distance Testing



Cleaning end face



Product Initial Test



Switch Testing



Product Final Test

Packaging

ETU-Link provides two kinds of packaging, 10pcs/Tray and individual package.



Company: ETU-Link Technology Co., LTD

Address: 4th Floor, C Building, JinBoLong Industrial Park, QingQuan Road, LongHua District, Shenzhen city, GuangDong

Tel: +86-755 2328 4603

Addresses and phone number also have been listed at www.etulinktechnology.com.

Please e-mail us at sales@etulinktechnology.com or call us for assistance.