

ESCxx2X-10D(I)

25Gb/s SFP28 CWDM 10km DDM Transceiver

PRODUCT FEATURES

- Support data rate up to 25.78125Gb/s
- Hot-Pluggable SFP Footprint and Single LC Connector
- Up to 10km reach for G.652 SMF
- 1270~1370nm CWDM DFB laser, 1470~1610nm CWDM EML laser and PIN receiver
- Temperature Range:
 - Commercial: 0°C ~70°C
 - Industrial: -40°C ~85°C
- Power consumption
 - Commercial: 1W(DFB), 1.5W(EML)
 - Industrial: 1.2W(DFB), 1.8W(EML)
- RoHS 6 compliance
- Digital Monitoring SFF-8472 Rev 10.2 compliant
- Compliant to IEEE 802.3cc, SFF-8419
- Complies with EU Directive 2015/863/EU

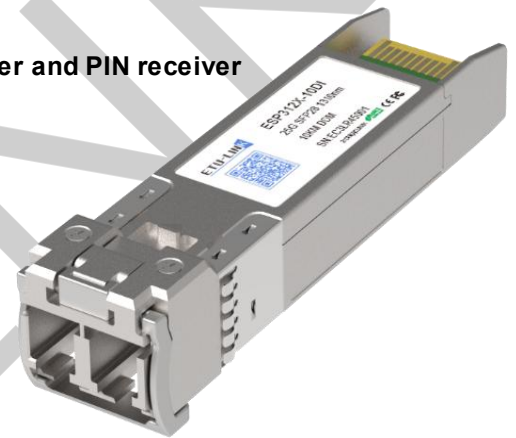

APPLICATIONS

- 25GBASE Ethernet
- CPRI option 10

DESCRIPTIONS

The ESCxx2X-10D(I) is a single Channel, Pluggable, Fiber Optic SFP28 for 25 Gigabit Ethernet Application. It is a high performance module for short-range data communication and interconnect applications which operate at 25.78125 Gbps up to 10km. They are compliant with SFF-8431 Rev 4.1, SFF-8432. The transmitter converts serial CML electrical data into serial optical data. The receiver converts serial optical data into serial CML electrical data. Digital diagnostics functions are available via a 2-wire serial interface, as specified in SFF-8472 Rev 12.1.

Module Block Diagram

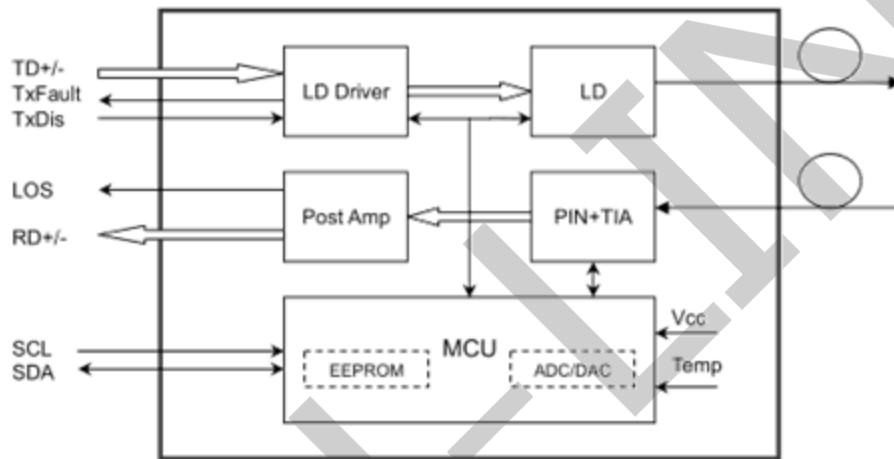

Ordering Information

Part No.	Data Rate (optical)	Laser	Fiber Type	Distance	Optical Interface	Temp	DDMI
ESCxx2X-10D	25.78125Gbps	DFB/EML	SMF	10km	LC	0~70°C	Y
ESCxx2X-10DI	25.78125Gbps	DFB/EML	SMF	10km	LC	-40~85°C	Y

Wavelength Guide Table

Part No.	Channel	Wavelength(nm)		
		min	typical	max
ESC272X-10D	C27	1264.5	1271	1277.5
ESC292X-10D	C29	1284.5	1291	1297.5
ESC312X-10D	C31	1304.5	1311	1317.5
ESC332X-10D	C33	1324.5	1331	1337.5
ESC352X-10D	C35	1344.5	1351	1357.5

ESC372X-10D	C37	1364.5	1371	1377.5
ESC472X-10D	C47	1464.5	1471	1477.5
ESC492X-10D	C49	1484.5	1491	1497.5
ESC512X-10D	C51	1504.5	1511	1517.5
ESC532X-10D	C53	1524.5	1531	1537.5
ESC552X-10D	C55	1544.5	1551	1557.5
ESC572X-10D	C57	1564.5	1571	1577.5
ESC592X-10D	C59	1584.5	1591	1597.5
ESC612X-10D	C61	1604.5	1611	1617.5
ESC272X-10DI	C27	1263.5	1271	1278.5
ESC292X-10DI	C29	1283.5	1291	1298.5
ESC312X-10DI	C31	1303.5	1311	1318.5
ESC332X-10DI	C33	1323.5	1331	1338.5
ESC352X-10DI	C35	1343.5	1351	1358.5
ESC372X-10DI	C37	1363.5	1371	1378.5
ESC472X-10D	C47	1464.5	1471	1477.5
ESC492X-10D	C49	1484.5	1491	1497.5
ESC512X-10D	C51	1504.5	1511	1517.5
ESC532X-10D	C53	1524.5	1531	1537.5
ESC552X-10D	C55	1544.5	1551	1557.5
ESC572X-10D	C57	1564.5	1571	1577.5
ESC592X-10D	C59	1584.5	1591	1597.5
ESC612X-10D	C61	1604.5	1611	1617.5

Notes:

- AsperITU-TG.694.2;

Absolute Maximum Ratings

Parameter	Symbol	Min.	Typical	Max.	Unit	Notes
Storage Temperature	T_{stg}	-40		+85	°C	
Case Operating Temperature(Commercial)	T_o	0		70	°C	
Case Operating Temperature (Industrial)	T_o	-40		85	°C	
Relative Humidity- Storage	R_{HS}	5		95	%	
Relative Humidity- Operating	R_{HO}	5		85	%	
DC Supply Voltage	V_{CC}	0		3.6	V	

Recommended Operating Conditions

Parameter	Symbol	Min.	Typical	Max.	Unit	Notes
Case Operating Temperature	T_{op}	0	-	70	°C	Commercial
		-40		85		Industrial
Power Supply Voltage	V_{CC}	3.13	3.3	3.47	V	

Transmission Distance	TD	-	-	10	km	Over SMF
-----------------------	----	---	---	----	----	----------

Electrical Characteristics

High-Speed Signal: Compliant to CEI-25G-VSR

Low-Speed Signal: Compliant to SFF-8419

Parameter	Symbol	Min.	Typical	Max.	Unit	Notes
Transmitter (Module Input)						
Differential Input Resistance	R _{R_{diff}}	90	100	110	Ω	
Input Differential Voltage	R _{V_{diff}}	-	-	900	mVpp	
Tx_Disable	Normal Operation	V _{IL}	-0.3	-	0.8	V
	Laser Disable	V _{IH}	2.0	-	V _{CC} +0.3	V
Receiver (Module Output)						
Differential Resistance	T _{R_d}	90	100	110	Ohm	
Output Differential Voltage	T _{V_{diff}}	-	-	900	mVpp	
Differential Termination Resistance Mismatch	T _{R_{dm}}	-	-	10	%	
Rx los	Normal Operation	V _{OL}	-0.3	-	0.4	V
	Loss Signal	V _{OH}	2	-	V _{CC} HOST	V

Optical and Characteristics

Parameter	Symbol	Min.	Typical	Max.	Unit	Notes
Transmitter						
Laser Safety	Class I according to IEC60825					
Optical Modulation Amplitude(OMA)	POMA	0		6	dBm	
Average Output Power	POUT	0		6	dBm	
Average Output Power(Laser Off)	POFF			-30	dBm	
Spectrum Bandwidth @ -20dB	Δλ			1	nm	
Side mode suppression ratio(SMSR)	SMSR	30			dB	
Extinction ratio	ER	3.5			dB	
RIN _{20OMA}	RIN			-130	dB/Hz	
Receiver						
Wavelength	λ	1260		1620	nm	
Received Sensitivity(OMA)	P _{SEN-OMA}			-13.3	dBm	2
Optical Power Overload	P _{IN(SAT)}	2			dBm	
Receiver Reflectance	RFL			-26	dB	
Rx_LOS of Signal Assert	P _A	-30			dBm	
Rx_LOS of Signal De-assert	P _D			-16	dBm	
Rx_LOS of Signal Hysteresis	P _{Hy}	0.5		5	dB	
Optical Return Loss Tolerance	ORLT	20			dB	

Notes:

1, Test pattern: PRBS31. BER<math>5 \times 10^{-5}</math>;

Digital Diagnostics

Parameter	Range	Accuracy	Unit	Calibration
Temperature	-40 to 85	± 3	$^{\circ}\text{C}$	Internal
Voltage	3.13 to 3.47	$\pm 3\%$	V	Internal
Tx Bias Current	0 to 100	$\pm 10\%$	mA	Internal
Tx Output Power	0 to 6	± 3	dB	Internal
Rx Input Power	-16 to 0	± 3	dB	Internal

Pin Diagram

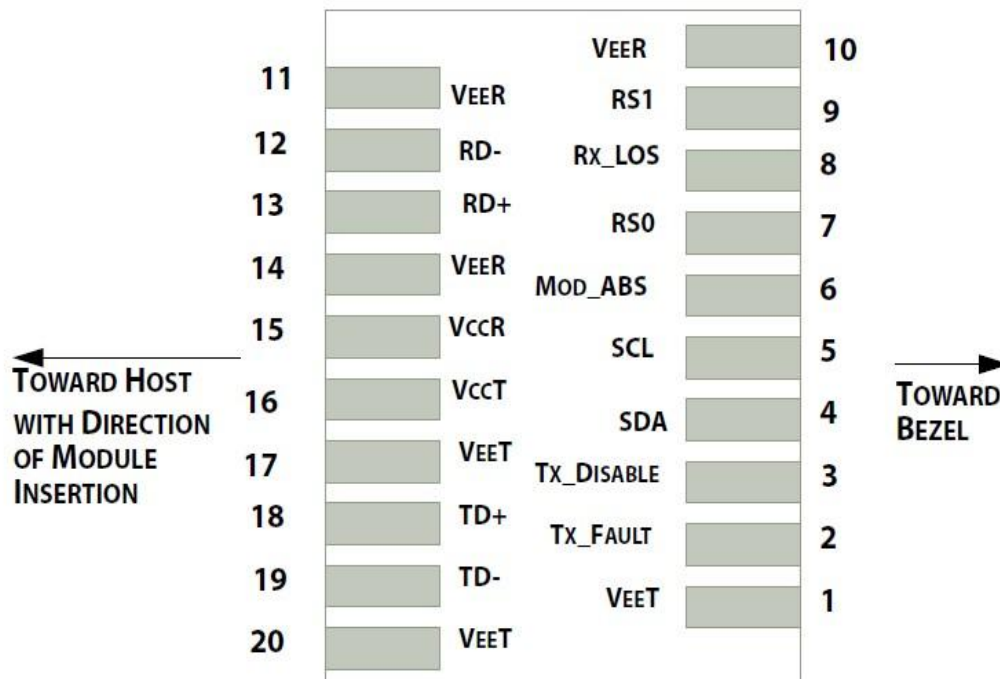

Pin Definitions

PIN #	Name	Function	Notes
1	VeET	Transmitter Ground	1
2	Tx Fault	Transmitter Fault - High indicates a fault condition	2
3	Tx Disable	Transmitter Disable – High or open disables the transmitter	
4	SDL	2-wire Serial Interface Data Line (MOD-DEF2)	3
5	SCL	2-wire Serial Interface Clock (MOD-DEF1)	3
6	MOD-ABS	Module Absent, connected to VeET or VeER in the module	
7	RS0	Rate Select 0	5
8	RX_LOS	Receiver Loss of Signal(LVTTL-O). Logic 0 indicates normal operation	4

9	RS1	Rate Select 1	1
10	VeeR	Receiver Ground	1
11	VeeR	Receiver Ground	1
12	RD-	Inverse Received Data out (CML-O), AC Coupled	
13	RD+	Receiver Non-inverted DATA out. AC Coupled	
14	VeeR	Receiver Ground	1
15	VccR	Receiver Power Supply	
16	VccT	Transmitter Power Supply	
17	VeeT	Transmitter Ground	1
18	TD+	Transmitter Non-Inverted DATA in. AC Coupled.	
19	TD-	Transmitter Inverted DATA in. AC Coupled.	
20	VeeT	Transmitter Ground	1

Notes:

1. Module ground pins GND are isolated from the module case.
2. Tx_Fault is an open collector/drain output, which should be pulled up with a 4.7k – 10k Ohms resistor on Host board.
3. Should be pulled up with 4.7k–10kohms on host board to a voltage between 2.0V and 3.6V.
4. LOS is open collector output. Should be pulled up with 4.7k–10kohms on host board to a voltage between 2.0V and 3.6V.
5. RS0 and RS1 pins are pulled low to GND with a resistor > 30KΩ in module.

Recommended Interface Circuit

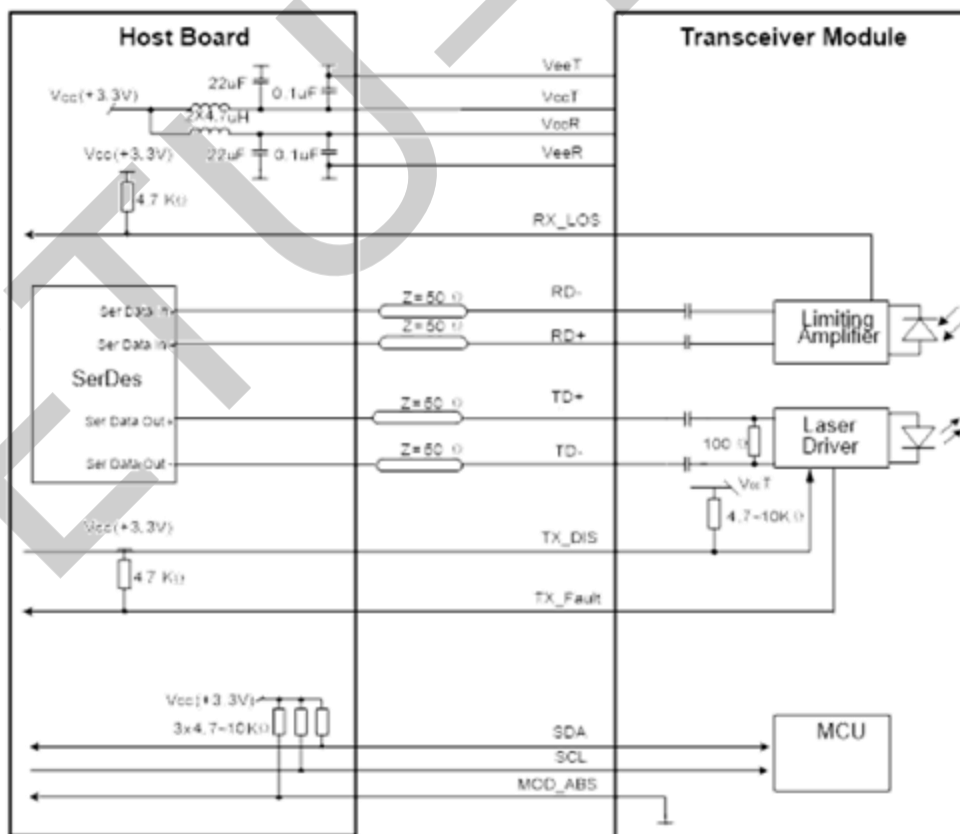

Mechanical Diagram

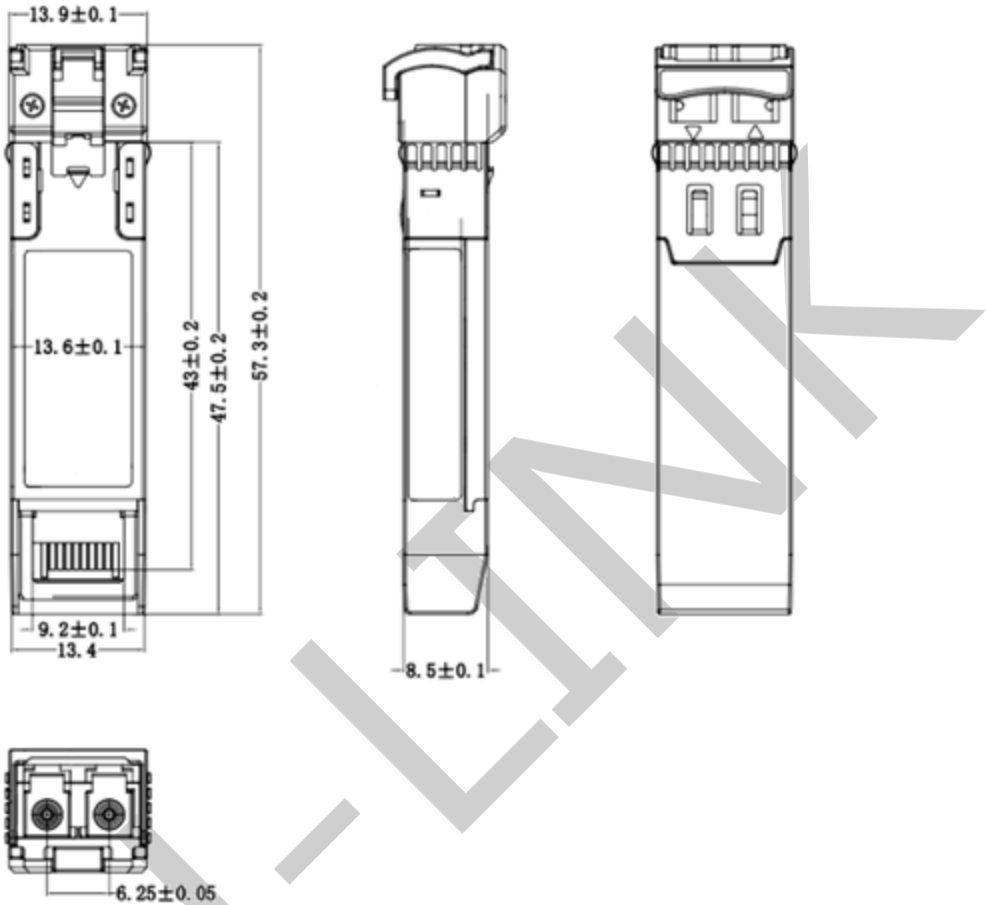

Revision History

Version No.	Date	Description
1.0	April,19, 2019	Preliminary datasheet
2.0	November,8,2023	Product upgrades
2.1	Aug 20, 2024	Format change
2.2	May 21th, 2026	Add the wavelengths of C47 to C61
2.3	May 21th, 2026	Add EML solution power consumption

Company: ETU-Link Technology Co., LTD
 Address: Right side of 3rd floor, No. 102 building, Longguan expressway, Dalang street, Longhua District, Shenzhen city, GuangDong Province,China 518109
 Tel: +86-755 2328 4603
 Addresses and phone number also have been listed at www.etulinktechnology.com.
 Please e-mail us at sales@etulinktechnology.com or call us for assistance.

ETU-LINK