

## XFP

### EXDxxX-3LCD100

#### 10Gb/s XFP DWDM 100km Optical Transceiver Module

- Supports 9.95Gb/s to 11.3Gb/s bit rates
- DWDM EML transmitter and APD receiver
- 100 GHz ITU channel spacing with integrated wavelength locker
- Up to 100km on 9/125μm SMF
- Hot-pluggable XFP footprint
- Supports Lineside and XFI loopback
- Built-in digital diagnostic functions
- Full Duplex LC connector
- RoHS-10 compliant and lead-free
- Single +3.3V power supply
- No Reference Clock required
- Power dissipation <2.0W
- Metal enclosure, for lower EMI
- Meet ESD requirements, resist 8KV direct contact voltage
- Case operating temperature
  - Commercial: 0 ~ +70°C
  - Extended: -10 ~ +80°C
  - Industrial: -40 ~ +85°C



## Applications

- 10GBASE-ZR/ZW & 10G Ethernet
- SONET OC-192 & SDH STM I-64.1
- 10G Fiber Channel

## Wavelength Selection

### C-band $\lambda_c$ Wavelength Guide Pin Descriptions

Channel	Wavelength (nm)	Frequency (THZ)	Channel	Wavelength (nm)	Frequency (THZ)
C17	1563.86	191.70	C39	1546.12	193.90
C18	1563.05	191.80	C40	1545.32	194.00
C19	1562.23	191.90	C41	1544.53	194.10
C20	1561.42	192.00	C42	1543.73	194.20
C21	1560.61	192.10	C43	1542.94	194.30
C22	1559.79	192.20	C44	1542.14	194.40
C23	1558.98	192.30	C45	1541.35	194.50
C24	1558.17	192.40	C46	1540.56	194.60
C25	1557.36	192.50	C47	1539.77	194.70
C26	1556.55	192.60	C48	1538.98	194.80
C27	1555.75	192.70	C49	1538.19	194.90
C28	1554.94	192.80	C50	1537.40	195.00
C29	1554.13	192.90	C51	1536.61	195.10
C30	1553.33	193.00	C52	1535.82	195.20
C31	1552.52	193.10	C53	1535.04	195.30
C32	1551.72	193.20	C54	1534.25	195.40
C33	1550.92	193.30	C55	1533.47	195.50
C34	1550.12	193.40	C56	1532.68	195.60
C35	1549.32	193.50	C57	1531.90	195.70
C36	1548.51	193.60	C58	1531.12	195.80
C37	1547.72	193.70	C59	1530.33	195.90
C38	1546.92	193.80	C60	1529.55	196.00
<b>Non-ITU</b>	Peak wavelength between 1528.77nm-1563.86		C61	1528.77	196.10

## Absolute Maximum Ratings

It has to be noted that the operation in excess of any individual absolute maximum ratings might cause permanent damage to this module.

Parameter	Symbol	Min	Max	Unit	Unit
Storage Temperature	T <sub>s</sub>	-40	85	°C	
Power Supply Voltage	V <sub>CC</sub>	-0.5	3.6	V	
Relative Humidity (non-condensation)	RH	5	95	%	
Damage Threshold	TH <sub>d</sub>	0		dBm	

## Recommended Operating Conditions and Power Supply Requirements

Parameter	Symbol	Min	Typical	Max	Unit	Notes
Operating Case Temperature	T <sub>OP</sub>	See order Information			°C	
Power Supply Voltage	V <sub>CC</sub>	3.135	3.3	3.465	V	
Data Rate			10.3125		Gb/s	
Control Input Voltage High		2		V <sub>CC</sub>	V	
Control Input Voltage Low		0		0.8	V	
Link Distance (SMF)	D			100	km	9/125um

## General Description

ETU-LINK's XFP transceiver is designed for use in 10-Gigabit Ethernet links up to 100km over single mode fiber. The module consists of DWDM EML Laser, APD and Preamplifier in a high-integrated optical sub-assembly. Digital diagnostics functions are available via a 2-wire serial interface, as specified in XFP MSA. This module is designed for single mode fiber and operates at a nominal wavelength of 100GHz ITU Grid, C Band DWDM wavelength.

transceivers provide a unique enhanced digital diagnostic monitoring interface, which allows real-time access to device operating parameters such as transceiver temperature, laser bias current, transmitted optical power, and received optical power and transceiver supply voltage. It also defines a sophisticated system of alarm and warning flags, which alerts end-users when particular operating parameters are outside of a factory set normal

range.

The XFP MSA defines a 256-byte memory map in EEPROM that is accessible over a 2-wire serial interface at the 8 bit address 1010000X (A0h). The digital diagnostic monitoring interface makes use of the 8 bit address 1010001X (A2h), so the originally defined serial ID memory map remains unchanged.

## Pin Assignment and Pin Description

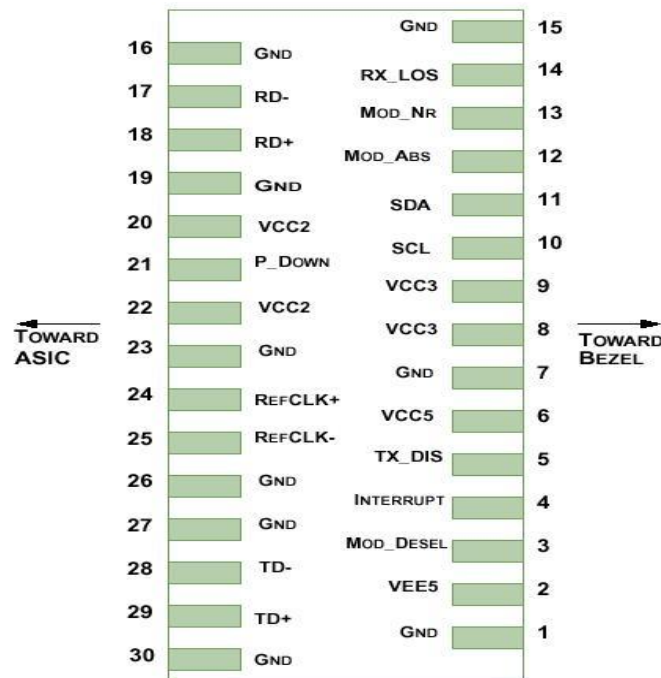

Figure1. Diagram of host board connector block pin numbers and names

Pin	Symbol	Name/Description	Notes
1	GND	Module Ground	1
2	VEE5	Optional -5.2 Power Supply – Not required	
3	Mod-Desel	Module De-select; When held low allows the module to respond to 2-wire serial interface commands	
4	Interrupt	Interrupt (bar); Indicates presence of an important condition which can be read over the serial 2-wire interface	2
5	TX_DIS	Transmitter Disable; Transmitter laser source turned off	
6	VCC5	+5 Power Supply – Not required	
7	GND	Module Ground	1
8	VCC3	+3.3V Power Supply	
9	VCC3	+3.3V Power Supply	
10	SCL	Serial 2-wire interface clock	
11	SDA	Serial 2-wire interface data line	2
12	Mod_Abs	Module Absent; Indicates module is not present. Grounded in the module.	2

13	Mod_NR	Module Not Ready; Walsun's defines it as a logical OR between RX_LOS and Loss of Lock in TX/RX.	2
14	RX_LOS	Receiver Loss of Signal indicator	2
15	GND	Module Ground	1
16	GND	Module Ground	1
17	RD-	Receiver inverted data output	
18	RD+	Receiver non-inverted data output	
19	GND	Module Ground	1
20	VCC2	+1.8V Power Supply – Not required	
21	P_Down/RST	Power Down; When high, places the module in the low power stand-by mode and on the falling edge of P_Down initiates a module reset	
		Reset; The falling edge initiates a complete reset of the module including the 2-wire serial interface, equivalent to a power cycle.	
22	VCC2	+1.8V Power Supply – Not required	
23	GND	Module Ground	1
24	RefCLK+	Reference Clock non-inverted input, AC coupled on the host board – Not required	3
25	RefCLK-	Reference Clock inverted input, AC coupled on the host board – Not required	3
26	GND	Module Ground	1
27	GND	Module Ground	1
28	TD-	Transmitter inverted data input	
29	TD+	Transmitter non-inverted data input	
30	GND	Module Ground	1

#### Notes:

1. Module circuit ground is isolated from module chassis ground within the module.
2. Open collector; should be pulled up with 4.7k $\Omega$ -10k $\Omega$  on host board to a voltage between 3.15V and 3.6V.
3. A Reference Clock input is not required by the HXXD-ALxxW1x. If present, it will be ignored.

## Electrical Characteristics

The following electrical characteristics are defined over the Recommended Operating Environment unless otherwise specified.

Parameter	Symbol	Min.	Typ.	Max	Unit	Notes
Power Consumption	P			2.0	W	1
Supply Current	I <sub>cc</sub>			580	mA	
<b>Transmitter</b>						
Single-ended Input Voltage Tolerance	V <sub>cc</sub>	-0.3		4.0	V	

Differential Input Voltage Swing	V <sub>in,pp</sub>	120		820	mVpp	
Differential Input Impedance	Z <sub>in</sub>	90	100	110	Ohm	2
Transmit Disable Assert Time				10	us	
Transmit Disable Voltage	V <sub>dis</sub>	V <sub>cc</sub> -1.3		V <sub>cc</sub>	V	3
Transmit Enable Voltage	V <sub>en</sub>	V <sub>ee</sub>		V <sub>ee</sub> +0.8	V	
<b>Receiver</b>						
Differential Output Voltage Swing	V <sub>out,pp</sub>	650		850	mVpp	
Differential Output Impedance	Z <sub>out</sub>	90	100	110	Ohm	4
Data output rise/fall time	Tr/Tf			38	ps	5
LOS Assert Voltage	V <sub>losH</sub>	V <sub>cc</sub> -1.3		V <sub>cc</sub>	V	6
LOS De-assert Voltage	V <sub>losL</sub>	V <sub>ee</sub>		V <sub>ee</sub> +0.8	V	6
Power Supply Rejection	PSR					7

## Notes:

1. Maximum total power value is specified across the full temperature and voltage range.
2. After internal AC coupling.
3. Or open circuit.
4. In to 100 ohms differential termination.
5. These are unfiltered 20-80% values
6. Loss of Signal is open collector to be pulled up with a 4.7kΩ-10kΩ resistor to 3.15-3.6V. Logic 0 indicates normal operation; logic 1 indicates no signal detected.
7. Per Section 2.7.1. in the XFP MSA Specification1.

## Optical Characteristics

Parameter	Symbol	Min.	Typical	Max	Unit	Notes
<b>Transmitter</b>						
Optical Wavelength	$\lambda_c$	$\lambda_c - 0.1$		$\lambda_c + 0.1$	nm	1
Center Wavelength Spacing			100		GHz	
Optical Spectral Width	$\Delta\lambda$			1	nm	
Side Mode Suppression Ratio	SMSR	30			dB	

Average Optical Power	$P_{AVG}$	1		5	dBm	2
Optical Extinction Ratio	ER	8.2			dB	
Transmitter and Dispersion Penalty	TDP			2	dB	
Transmitter OFF Output Power	POff			-30	dBm	
Transmitter Eye Mask		Compliant with IEEE802.3ae				
<b>Receiver</b>						
Center Wavelength	$\lambda_c$	1270		1610	nm	
Receiver Sensitivity (Average Power)	Sen.			-25	dBm	3
Input Saturation Power (overload)	Psat	-8			dBm	
LOS Assert	LOSA	-37			dB	
LOS De-assert	LOSD			-27	dBm	
Receiver Reflectance	Rrx			-27	dB	
LOS Hysteresis	LOSH	0.5			dBm	

The following optical characteristics are defined over the Recommended Operating Environment unless otherwise specified.

Notes:

1.  $\lambda_c$  refer to wavelength selection, and corresponds to approximately 0.8 nm
2. Class 1 Laser Safety per FDA/CDRH and IEC-825-1 regulations.
3. Measured with Light source 1528.77~1563.86nm, ER=8.2dB; BER =<math>10^{-12}</math> @10.3125Gbps, PRBS=2<sup>31</sup>-1 NRZ.

## Digital Diagnostic Functions

The following digital diagnostic characteristics are defined over the normal operating conditions unless otherwise specified.

Parameter	Symbol	Min.	Max	Unit	Notes
Temperature monitor absolute error	DMI_Temp	-3	3	degC	Over operating temp
Supply voltage monitor absolute error	DMI_VCC	-0.1 5	0.15	V	Full operating range
RX power monitor absolute error	DMI_RX	-3	3	dB	
Bias current monitor	DMI_bias	-10 %	10%	mA	
TX power monitor absolute error	DMI_TX	-3	3	dB	

## Mechanical Dimensions

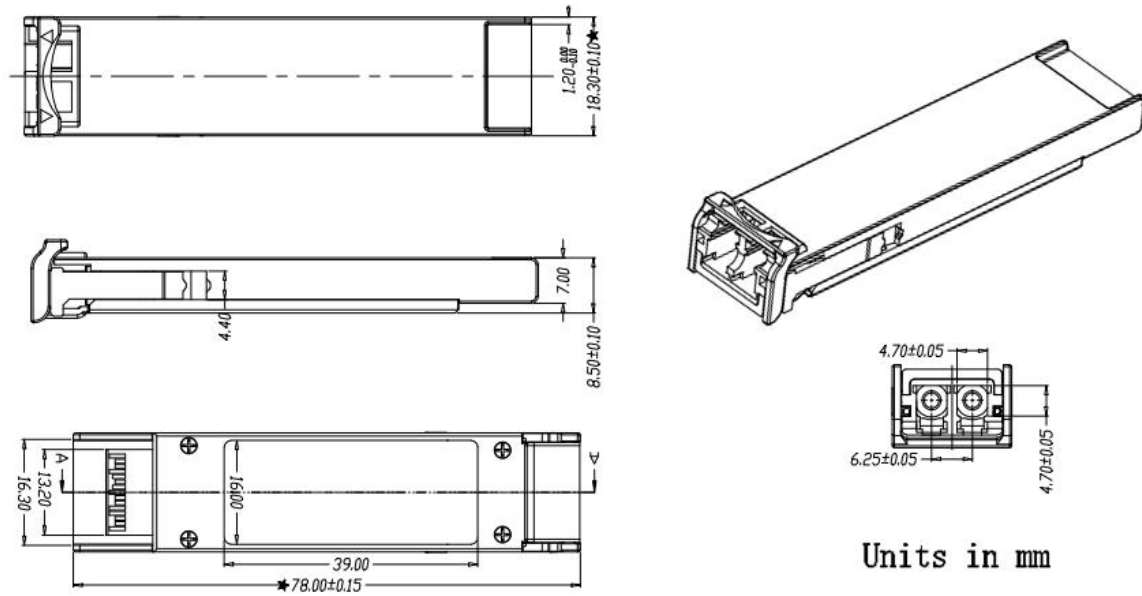

Figure2. Mechanical Outline

## Precautions

- This device is susceptible to damage as a result of electrostatic discharge (ESD). A static free environment is highly recommended. Follow guidelines according to proper ESD procedures.
- Radiation emitted by laser devices can be dangerous to human eyes. Avoid eye exposure to direct or indirect radiation.



## Compatibility Test

In order to ensure the product compatibility, our products will be tested on the switch before shipment. Our modules can compatible with many mainstream brand switches, such as Cisco, Juniper, Extreme, Brocade, IBM, H3C, HP, Huawei, D-Link, Mikrotik, ZTE, TP-Link...

Our test equipment: VOLKTEK MEN-4110, HP 2530-8G, CRS226-24G-25+RM, Catalyst 2960G Series, Catalyst 3850 XS 10G SFP+, Catalyst 3750-E Series, HUAWEI S5700Series, H3C S3100V2 Series, Juniper-EX4200, etc.



**Cisco Catalyst 3850**



**HUAWEI S5700**



**H3C S3100V2**



**HP J9264AR**



**Juniper EX 4200**



**Alcatel 6850E-U24X**



**Mikrotik CR5226-24G-25+RM**



**Cisco Catalyst 2960G**



**Volktek MEN-4110**

## Product Production Process

# Quality Assurance

Continuous introduction of new equipment, produced by strict standards, strict quality inspection, to guarantee the high quality standard of each product.



**Standardized  
Production Line**



**Professional  
Welding**



**Assembling**



**Aging Testing**

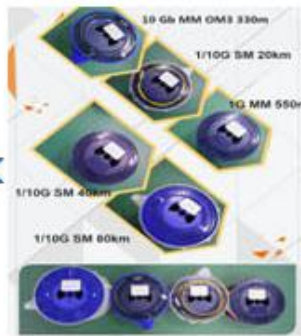

**Distance Testing**



**Cleaning end face**



**Product Initial Test**



**Switch Testing**



**Product Final Test**

## Packaging

ETU-Link provides two kinds of packaging, 10pcs/Tray and individual package.



Company: ETU-Link Technology Co., LTD

Address: Right side of 3rd floor, No. 102 building, Longguan expressway, Dalang street, Longhua District, Shenzhen city, Guangdong Province, China 518109

Tel: +86-755 2328 4603

Addresses and phone number also have been listed at [www.etulinktechnology.com](http://www.etulinktechnology.com).

Please e-mail us at [sales@etulinktechnology.com](mailto:sales@etulinktechnology.com) or call us for assistance.